



Compressed air treatment

for applications up to 2,500 m³/h and 16 bar



What is ...?

Compressed air

is energy in the form of compressed ambient air. Compressed air is permanently trying to expand back to atmospheric pressure and thus performs work during the expansion process. Besides electrical energy compressed air is one of the most important forms of power for industrial production processes and is widely used thanks to numerous advantages:

- Can be produced locally and on demand
- Can be stored easily and without losses
- Can be transported easily
- High amount of energy per volume
- Can be easily converted to other forms of energy, e.g. blast air, fast linear movement with increased force, rotary movement with increased torque, in a space-saving way
- Versatile applications

The compressed air contains all kind of contamination and moisture from the ambient air, which are concentrated according to the operating pressure. Oil-lubricated compressors will add amounts of oil to the compressed air. When the compressed and hot air is cooled down to an appropriate operating temperature, larger amounts of water will condense (condensate).

Untreated contamination in the compressed air would contaminate and damage the compressed air system, the compressed air consumers and the products that come into contact with the compressed air.

Compressed air treatment

removes the unwanted contamination and provides the purity of the compressed air required for the application, e.g. standard instrument air, technically oil-free compressed air up to sterile ultra-pure air or medical breathing air. Many industries have a specific air quality requirement governed by best practice or legislation.

The aim of compressed air treatment is to ensure continuous and trouble-free operation of applications using compressed air, to minimise downtimes, unscheduled maintenance and repair work, and to remove specific contamination that may be harmful to the product.

And, most of all, compressed air treatment actively contributes to environmental protection as well as to occupational health and safety. Liquid oil droplets, finest oil mist, oil-contaminated solid particles and gaseous, foul-smelling oil vapour, i.e. contamination which occurs on site during compressed air production,

can be completely eliminated and thus will not contaminate the local environment.

The compressed air treatment system comprises several consecutive treatment components, referred to as treatment chain, which treat the compressed air in stages in order to achieve the required purity.

Basic compressed air treatment divides into the three main categories:

- water separation / filtration
- cooling / drying
- oil vapour adsorption

Condensate technology

is applied to almost every component of the treatment chain. It is divided into the condensate discharge and condensate treatment. In the condensate discharge process, amounts of liquid generated by means of condensation or specific separation, are removed from the compressed air system. As a result, carryover of liquid contamination throughout the treatment chain is avoided. The condensate treatment process is used to clean the condensate from dirt, oil and hydrocarbon. The condensate may then enter the wastewater system or a river, lake or similar in an ecologically compatible way.





This brochure ...

is a compilation of our comprehensive main product brochures, offering a selection and basic information of essential compressed air treatment components for applications up to 2,500 m³/h at operating pressures up to 16 bar in just one document.

For advanced information and further compressed air treatment products for volume flows up to 30,000 m³/h and working pressures up to 350 bar please refer to the according main product brochure and product data sheets.

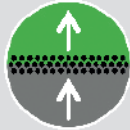

Compressed air treatment components

 Water separator Filter	 Refrigeration dryer	 Adsorption dryer	 Oil vapour adsorber	 Condensate technology
Page 4-5	Page 6-7	Page 8-9	Page 10-11	Page 12-13
<p>Water separators and filters remove all types of solid and liquid contaminants in stages, i.e. large amounts of condensate and coarse contamination particles such as rust, abrasion particles, oil droplets and dust are filtered in the first stages and then fine oil mist and fine dust particles are filtered in subsequent stages. Filters containing activated carbon also remove foul-smelling odours and oil vapour.</p>	<p>Refrigeration dryers eliminate moisture and thus produce dry, undersaturated compressed air down to pressure dew-points of +3°C thus ensuring no further condensation can occur in the downstream compressed air system – as long as the compressed air temperature doesn't fall below the pressure dew-point.</p>	<p>Adsorption dryers eliminate moisture and thus produce dry, undersaturated compressed air down to pressure dew-points of -70°C thus ensuring no further condensation can occur in the downstream compressed air system – offering super-dry compressed air suitable for outdoor installations and applications demanding a very high compressed air purity.</p>	<p>Activated carbon oil vapour adsorber reduce the oil vapour content of the compressed air down to residual levels of ≤ 0.003 mg/m³ thus ensuring no condensation of liquid oil can occur in the downstream compressed air system. In addition, a variety of other hydrocarbons, odours and flavours are removed as well.</p>	<p>Condensate drains discharge amounts of liquid from the compressed air system, thus avoiding carryover of liquid contamination throughout the treatment chain. Oil/water separators clean the condensate from dirt, oil and hydrocarbon. The condensate may then enter the waste-water system or a river, lake or similar in an ecologically compatible way.</p>

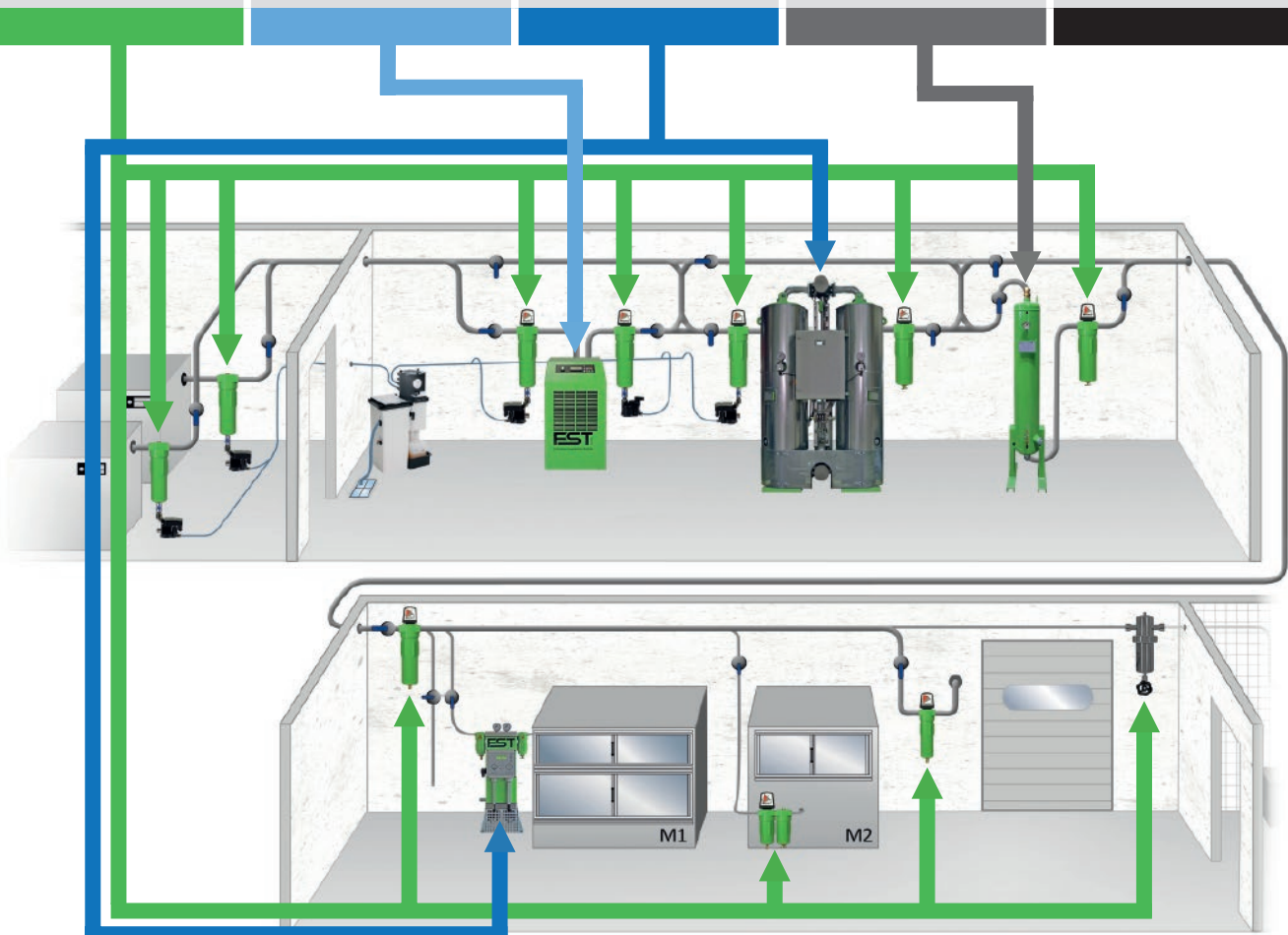

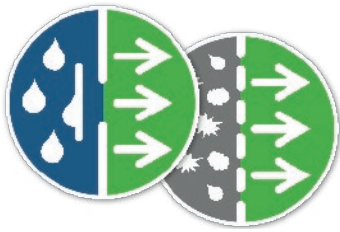

FCA, FWS series

Water separator

Wet- and dry-type separation filter (coalescing and dust filter)

Activated carbon filter



FCA series



FWS series







The advantages...

- ✓ **Rugged aluminium die-cast housing with double surface protection (FCA)**
 - passivation (chrome-VI free) and powder coating
 - no corrosion
 - long service life
- ✓ **Rugged welded steel housing with double surface protection (FWS)**
 - primer and wet-paint coatings
 - no rust formation
 - long service life
- ✓ **Validated pleated filter elements**
 - increased separation performance
 - low differential pressure
 - high dirt holding capacity
 - long service life
- ✓ **Validated activated carbon cartridges with 100% activated carbon granulate**
 - increased amounts of activated carbon
 - long service life
- ✓ **Filter elements with plug-in connection, a housing thread protected against overstress and the 1-person-easy-maintenance-concept**
 - easy filter element replacement
 - reliable sealing between filter housing and filter element

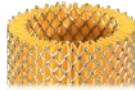
...result in a filter providing...

- ✓ maximum operational reliability
- ✓ minimum total operating costs
- ✓ long service life
- ✓ easy maintenance





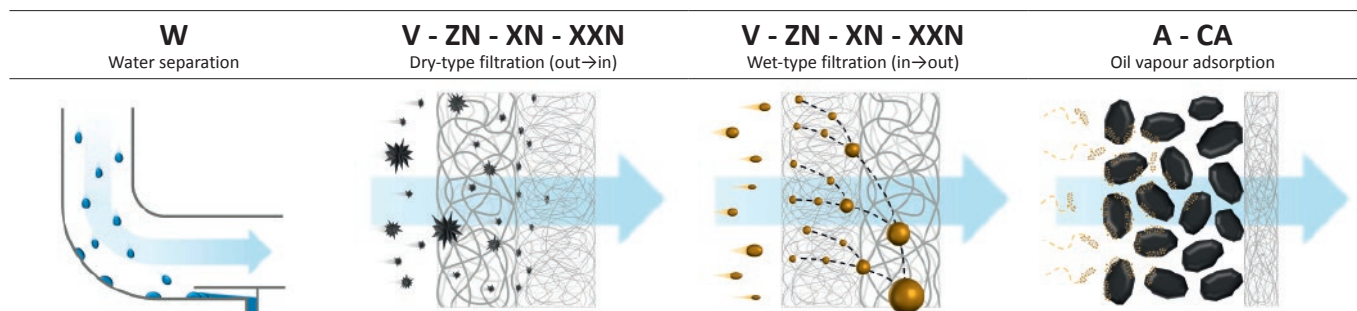

Filtration grades

W	V	ZN	XN	XXN	A	CA
Water separator	Coarse filter	Gen. purpose filter	Fine filter	Super fine filter	Activated carbon	Activated carbon
						
99.9% (100µ)	99.99% (3µ)	99.9999% (1µ) ≤ 0.5 mg/m ³ Residual oil (liquid)	99.9999% (0.01µ) ≤ 0.01 mg/m ³ Residual oil (liquid)	99.99999% (0.01µ) ≤ 0.001 mg/m ³ Residual oil (liquid)	≤ 0.003 mg/m ³ Residual oil (vapour)	≤ 0.003 mg/m ³ Residual oil (vapour)

Working principles



Accessories

Differential pressure gauge with/without alarm contact	Oil indicator	Manual drain	Automatic condensate drain	Electronic condensate drain	Wall brackets
					
from FCA30	from FCA30				up to FCA130

Technical data

Model	Nominal volume flow ¹	Max. allowable operating pressure	Compressed air connection	Filter element model	Height	Width	Depth	Weight
FCA20	30 m ³ /h	16 bar	G 1/4	EFST25	136 mm	61 mm	60 mm	0.5 kg
FCA25	35 m ³ /h	16 bar	G 3/8	EFST25	136 mm	61 mm	60 mm	0.5 kg
FCA30	50 m ³ /h	16 bar	G 3/8	EFST30	183 mm	87 mm	80 mm	1.0 kg
FCA50	70 m ³ /h	16 bar	G 1/2	EFST50	183 mm	87 mm	80 mm	1.0 kg
FCA70	100 m ³ /h	16 bar	G 1/2	EFST70	253 mm	87 mm	80 mm	1.1 kg
FCA90	160 m ³ /h	16 bar	G 3/4	EFST90	289 mm	130 mm	122 mm	3.9 kg
FCA95	160 m ³ /h	16 bar	G 1	EFST90	289 mm	130 mm	122 mm	3.8 kg
FCA110	330 m ³ /h	16 bar	G 1	EFST110	387 mm	130 mm	122 mm	4.3 kg
FCA115	330 m ³ /h	16 bar	G 1½	EFST110	387 mm	130 mm	122 mm	4.1 kg
FCA120	500 m ³ /h	16 bar	G 1½	EFST120	487 mm	130 mm	122 mm	4.7 kg
FCA130	800 m ³ /h	16 bar	G 1½	EFST130	689 mm	130 mm	122 mm	5.7 kg
FCA140	1,000 m ³ /h	16 bar	G 2	EFST140	670 mm	164 mm	146 mm	7.8 kg
FCA170	1,500 m ³ /h	16 bar	G 2	EFST170	923 mm	164 mm	146 mm	9.5 kg
FCA180	2,000 m ³ /h	16 bar	G 2½	EFST180	897 mm	250 mm	225 mm	22.9 kg
FCA185	2,000 m ³ /h	16 bar	G 3	EFST180	897 mm	250 mm	225 mm	22.4 kg
FCA190	2,500 m ³ /h	16 bar	G 3	EFST190	1049 mm	250 mm	225 mm	24.5 kg
FWS170	1,500 m ³ /h	16 bar	DN80	EFST170	1115 mm	440 mm	285 mm	46 kg
FWS190	2,500 m ³ /h	16 bar	DN80	EFST190	1115 mm	440 mm	285 mm	44 kg

¹ - standardized to 1 bar(a) and 20°C for operating conditions 7 bar operating pressure ; at deviating operating conditions conversion factors must be applied.



DFX, DFE series

Fridge drying down to
pressure dew-points of +3°C

The advantages...

- ✓ **Fully integrated, complete thermally insulated heat exchanger**
 - low differential pressure
 - leak-free
 - minimal thermal loss
- ✓ **High degree of overload protection**
 - reliable drying even under occasional unfavourable conditions
- ✓ **Energy saving control system (DFE)**
 - energy savings in partial load mode usually 20-60%
- ✓ **Level controlled condensate drains**
 - demand-driven, automatic and loss-free condensate discharge
- ✓ **Fine model range**
 - 22 models enable performance and cost optimised model selection
- ✓ **Robust metal housing**
 - sturdy housing with thick walls
 - high quality, long life powder coating
- ✓ **Removable side panels**
 - spacious access
 - easy cleaning and maintenance
- ✓ **Simple, space-saving installation**
 - inputs and outputs on the side/top
 - can be directly placed next to a wall
 - ready for wall mounting (DFX 2-15)
- ✓ **Comprehensive standard equipment**

..result in a dryer providing..

- ✓ maximum operational reliability
- ✓ minimum total operating costs
- ✓ long service life
- ✓ easy maintenance



Working principle

- ① air-to-air heat exchanger
- ② refrigerant-to-air heat exchanger
- ③ refrigerant circuit
- ④ condensate collecting area
- ⑤ condensate drain

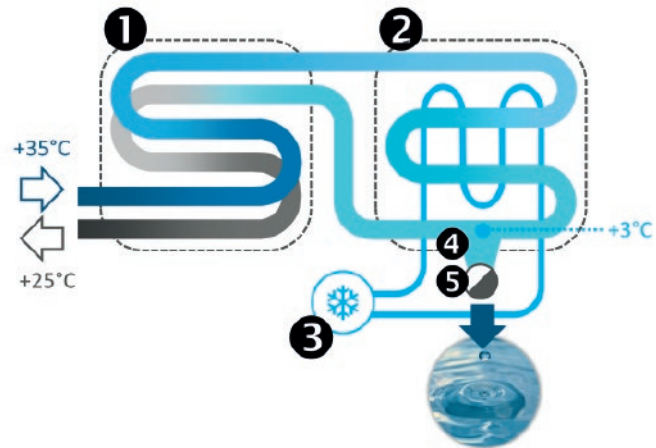

Accessories

Bypass line



Switch-over control



Technical data

Model	Nominal volume flow ^{*1}	Min./Max. allow operating pressure	Connection	Supply voltage	Height	Width	Depth	Weight
DFX 2	20 m³/h	2 - 16 bar	G 3/8	230 V / 50-60 Hz	645 mm	360 mm	410 mm	24 kg
DFX 4	35 m³/h	2 - 16 bar	G 1/2		645 mm	360 mm	410 mm	26 kg
DFX 5	50 m³/h	2 - 16 bar	G 1/2		645 mm	360 mm	410 mm	27 kg
DFX 7	65 m³/h	2 - 16 bar	G 1/2		645 mm	360 mm	410 mm	29 kg
DFX 9	85 m³/h	2 - 16 bar	G 1/2		645 mm	360 mm	410 mm	31 kg
DFX 11	105 m³/h	2 - 16 bar	G 1/2		645 mm	360 mm	410 mm	31 kg
DFX 13	125 m³/h	2 - 14 bar	G 1		645 mm	360 mm	410 mm	33 kg
DFX 15	150 m³/h	2 - 14 bar	G 1		645 mm	360 mm	410 mm	33 kg
DFX 18	180 m³/h	2 - 14 bar	G 1 ¼	230 V / 50 Hz	870 mm	480 mm	660 mm	55 kg
DFX 23	225 m³/h	2 - 14 bar	G 1 ¼		870 mm	480 mm	660 mm	56 kg
DFX 30	300 m³/h	2 - 14 bar	G 1 ¼		870 mm	480 mm	660 mm	57 kg
DFX 36	360 m³/h	2 - 14 bar	G 1 ½		870 mm	480 mm	660 mm	61 kg
DFX 45	450 m³/h	2 - 14 bar	G 1 ½		870 mm	480 mm	660 mm	68 kg
DFX 55	550 m³/h	2 - 14 bar	G 2		1055 mm	645 mm	920 mm	116 kg
DFX 65	650 m³/h	2 - 14 bar	G 2		1055 mm	645 mm	920 mm	118 kg
DFX 75	750 m³/h	2 - 14 bar	G 2		1055 mm	645 mm	920 mm	121 kg
DFX 85	850 m³/h	2 - 14 bar	G 2	1055 mm	645 mm	920 mm	155 kg	
DFE 55	550 m³/h	2 - 16 bar	G 2	400 V / 50 Hz	1230 mm	904 mm	805 mm	150 kg
DFE 65	650 m³/h	2 - 16 bar	G 2		1230 mm	904 mm	805 mm	152 kg
DFE 75	750 m³/h	2 - 16 bar	G 2		1230 mm	904 mm	805 mm	166 kg
DFE 85	850 m³/h	2 - 16 bar	G 2		1230 mm	904 mm	805 mm	175 kg
DFE 100	1,000 m³/h	2 - 16 bar	G 2 ½		1230 mm	904 mm	805 mm	177 kg
DFE 120	1,175 m³/h	2 - 16 bar	G 2 ½		1230 mm	904 mm	805 mm	180 kg
DFE 135	1,350 m³/h	2 - 16 bar	G 2 ½		1230 mm	904 mm	805 mm	185 kg
DFE 150	1,500 m³/h	2 - 16 bar	G 2 ½		1230 mm	904 mm	805 mm	190 kg
DFE 165	1,650 m³/h	2 - 16 bar	G 2 ½	1230 mm	904 mm	805 mm	196 kg	

*1 - standardized to 1 bar(a) and 20°C for operating conditions 7 bar operating pressure, inlet temperature 35°C, pressure dew-point at outlet 5°C (DFX) resp. 3°C (DFE); at deviating operating conditions conversion factors must be applied.



DPS series

Adsorption drying – heatless regeneration –
down to pressure dew-points of -25°C / -40°C / -70°C



DPS 1-8



DPS 10-240

The advantages...

- ✓ **Pressure vessels MADE IN GERMANY**
 - meet the highest safety standards
 - high quality, durable coating
- ✓ **Molecular sieve desiccant**
 - high quality, effective desiccant
 - stable pressure dew-points down to -70°C
 - energy-saving cycle time of 10 minutes
- ✓ **2-layer desiccant bed**
 - stable drying
 - extended desiccant service life
- ✓ **Evenly distributed flow through stainless steel screen/demister**
 - maximum drying efficiency
 - low differential pressures
 - extended desiccant service life
- ✓ **Individual valve control**
 - no pressure peaks during switch-over
 - reliable compressed air supply
- ✓ **Compact valve blocks (up to DPS 100)**
 - practically leak-free
 - easy, cost-effective service
- ✓ **C1 control unit**
 - plain test display
 - prepared for dew-point dependent control with variable cycle
 - individual choice of alarm management
 - ... and much more



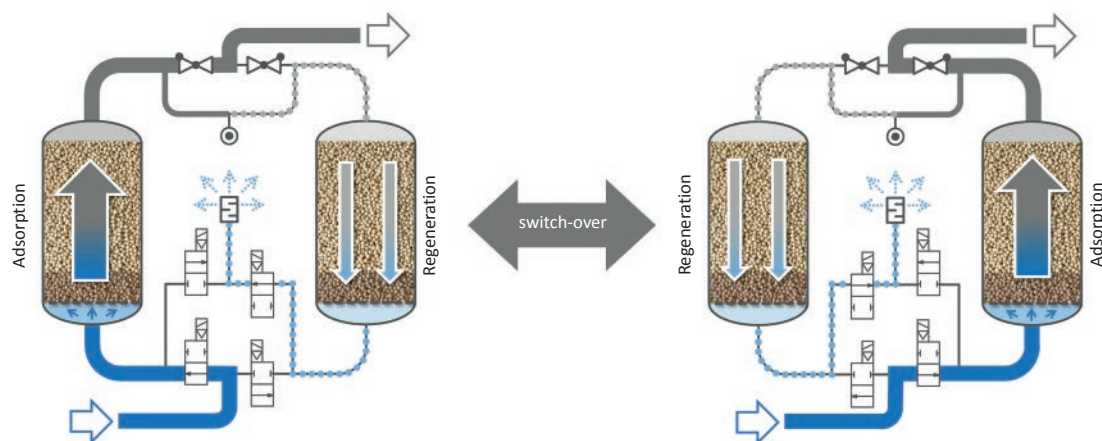

..result in a dryer providing..

- ✓ maximum operational reliability
- ✓ minimum total operating costs
- ✓ long service life
- ✓ easy maintenance

Working principle



Accessories

Dew-point sensor	Differential pressure gauges with alarm contact	Start-up device (minimum pressure valve)	GSM module	Switch-over control
				

Many other options, such as a frost protection, pneumatic control, special coatings, enhanced noise reduction, quick-closing valves, are available on request.

Technical data

Model	Nominal volume flow* ¹	Min./Max. allow. operating pressure	Connection	Supply voltage	Height	Width	Depth	Weight
DPS 1	8 m ³ /h	4 - 16 bar	G 3/8	230 V / 50-60 Hz 115 V / 50-60 Hz 24 V DC	450 mm	312 mm	185 mm	11 kg
DPS 2	15 m ³ /h	4 - 16 bar	G 3/8		625 mm	312 mm	185 mm	15 kg
DPS 3	25 m ³ /h	4 - 16 bar	G 3/8		875 mm	312 mm	185 mm	20 kg
DPS 4	35 m ³ /h	4 - 16 bar	G 3/8		1125 mm	312 mm	185 mm	25 kg
DPS 6	57 m ³ /h	4 - 16 bar	G 1/2		1180 mm	484 mm	220 mm	45 kg
DPS 7	72 m ³ /h	4 - 16 bar	G 1/2		1405 mm	484 mm	220 mm	54 kg
DPS 8	82 m ³ /h	4 - 16 bar	G 1/2		1605 mm	484 mm	220 mm	62 kg
DPS 10	110 m ³ /h	4 - 16 bar	G 1		1460 mm	675 mm	515 mm	126 kg
DPS 15	150 m ³ /h	4 - 16 bar	G 1		1700 mm	675 mm	515 mm	142 kg
DPS 20	200 m ³ /h	4 - 16 bar	G 1		1720 mm	675 mm	515 mm	180 kg
DPS 25	260 m ³ /h	4 - 16 bar	G 1		1735 mm	675 mm	515 mm	220 kg
DPS 30	320 m ³ /h	4 - 16 bar	G 1 ½		1830 mm	745 mm	555 mm	250 kg
DPS 40	410 m ³ /h	4 - 16 bar	G 1 ½		1840 mm	755 mm	570 mm	280 kg
DPS 60	590 m ³ /h	4 - 16 bar	G 1 ½		1870 mm	775 mm	600 mm	355 kg
DPS 80	770 m ³ /h	4 - 16 bar	G 2		2045 mm	1045 mm	715 mm	470 kg
DPS 100	1,000 m ³ /h	4 - 16 bar	G 2		2060 mm	1050 mm	750 mm	560 kg
DPS 120	1,200 m ³ /h	4 - 11 bar	DN 50		1975 mm	1110 mm	670 mm	670 kg
DPS 150	1,480 m ³ /h	4 - 11 bar	DN 65		2070 mm	1250 mm	870 mm	850 kg
DPS 210	2,080 m ³ /h	4 - 11 bar	DN 65		2090 mm	1340 mm	920 mm	1080 kg
DPS 240	2,430 m ³ /h	4 - 11 bar	DN 80		2185 mm	1520 mm	970 mm	1300 kg

*1 - standardized to 1 bar(a) and 20°C for operating conditions 7 bar operating pressure, inlet temperature 35°C, pressure dew-point at outlet -40°C; at deviating operating conditions conversion factors must be applied.

DPS 1-100 option for additional, integrated activated carbon stage (DPS..A)

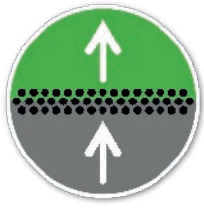

DSS series

Activated carbon oil vapour adsorption
for residual levels down to $\leq 0,003 \text{ mg/m}^3$



The advantages...

- ✓ **Pressure vessels MADE IN GERMANY**
 - meet highest safety standards
 - high-quality, durable coating
- ✓ **Activated carbon pellets**
 - high-quality, compressed activated carbon pellets with low dust level
- ✓ **Loose filling**
 - maximum amount of activated carbon
 - easy, environmentally friendly maintenance
- ✓ **Stainless steel flow distributor at inlet and outlet**
 - uniform flow distribution
 - reduced dust formation
- ✓ **Low dust level at outlet through stainless steel screen/demister**
 - reduced dust formation
 - easy maintenance
- ✓ **Oil indicator as standard**
 - controls the saturation level of the activated carbon
 - control point with lifetime reserve
- ✓ **Vessel pressure gauge (DSS 10-630)**
 - visual display of the operating situation
 - ensures depressurised state before maintenance work

..result in an adsorber providing..

- ✓ maximum operational reliability
- ✓ long service life
- ✓ easy maintenance

Working principle



Accessories

Pre- and after-filter



Technical data

Model	Nominal volume flow ^{*1}	Max. allowable operating pressure	Compressed air connection	Height	Width	Depth	Weight
DSS 1 A	8 m ³ /h	16 bar	G 3/8	392 mm	160 mm	210 mm	3 kg
DSS 2 A	15 m ³ /h	16 bar	G 3/8	567 mm	160 mm	210 mm	5 kg
DSS 3 A	25 m ³ /h	16 bar	G 3/8	817 mm	160 mm	210 mm	8 kg
DSS 4 A	35 m ³ /h	16 bar	G 3/8	1067 mm	160 mm	210 mm	10 kg
DSS 6 A	57 m ³ /h	16 bar	G 1/2	1107 mm	212 mm	245 mm	20 kg
DSS 7 A	72 m ³ /h	16 bar	G 1/2	1332 mm	212 mm	245 mm	24 kg
DSS 8 A	82 m ³ /h	16 bar	G 1/2	1532 mm	212 mm	245 mm	28 kg
DSS 10 A	110 m ³ /h	16 bar	G 1	1460 mm	265 mm	350 mm	45 kg
DSS 15 A	150 m ³ /h	16 bar	G 1	1700 mm	265 mm	350 mm	52 kg
DSS 20 A	200 m ³ /h	16 bar	G 1	1710 mm	290 mm	350 mm	67 kg
DSS 25 A	260 m ³ /h	16 bar	G 1	1720 mm	320 mm	350 mm	80 kg
DSS 30 A	320 m ³ /h	16 bar	G 1 ½	1760 mm	345 mm	350 mm	95 kg
DSS 40 A	410 m ³ /h	16 bar	G 1 ½	1820 mm	375 mm	350 mm	107 kg
DSS 60 A	590 m ³ /h	16 bar	G 1 ½	1850 mm	425 mm	350 mm	143 kg
DSS 80 A	770 m ³ /h	16 bar	G 2	1980 mm	460 mm	400 mm	190 kg
DSS 100 A	1,000 m ³ /h	16 bar	G 2	2000 mm	515 mm	400 mm	230 kg
DSS 120 A	1,200 m ³ /h	11 bar	DN 50	2020 mm	450 mm	570 mm	260 kg
DSS 150 A	1,480 m ³ /h	11 bar	DN 65	2070 mm	500 mm	650 mm	325 kg
DSS 210 A	2,080 m ³ /h	11 bar	DN 65	2100 mm	600 mm	745 mm	410 kg
DSS 240 A	2,430 m ³ /h	11 bar	DN 80	2200 mm	650 mm	800 mm	495 kg

*1 - standardized to 1 bar(a) and 20°C for operating conditions 7 bar operating pressure ; at deviating operating conditions conversion factors must be applied.



CDE-L series

Electronic, level controlled condensate discharge
for discharge quantities of up to 22 litres/hour (at 7 bar)



CDE 4-40

Working principle

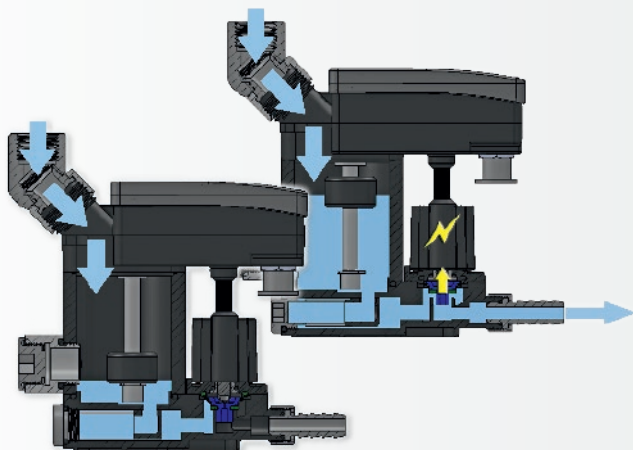

The advantages...

- ✓ **Automatic, loss-free, electronically controlled and monitored condensate discharge**
- ✓ **Contact-free, non-wearing magnetic-core level measurement**
 - fixed switching points at minimum and maximum levels independent of the type of condensate (oil or water)
 - long service life of the valve diaphragm
 - no calibration required
 - one drain for all types of condensate
- ✓ **Comprehensive information**
 - information about the current operating state
 - information if there is no incoming condensate and thus detection of condensate backup in the compressed air system
- ✓ **Integrated dirt screen**
- ✓ **Alarm message when dirt screen is blocked**
- ✓ **Easy to install and maintain**
 - condensate inlet with integrated threaded joint can be turned
 - screw-type or plug-type connections
 - only one maintenance kit for all models

..result in a condensate drain providing..

- ✓ maximum operational reliability
- ✓ long service life
- ✓ easy and flexible installation
- ✓ easy maintenance

Accessories

Mounting kits



Technical data

Model	Nominal volume flow after-cooler ^{*1}	Nominal volume flow refrigeration dryer ^{*1}	Nominal volume flow filter	Maximum discharge quantity	Min./Max. allow. operating pressure	Display Alarm contact
CDE4L	250 m ³ /h	500 m ³ /h	2,500 m ³ /h	2.2 Liter/h	1 - 16 bar	–
CDE8LC	500 m ³ /h	1,000 m ³ /h	5,000 m ³ /h	4.4 Liter/h	1 - 16 bar	Ja
CDE16LC	1,000 m ³ /h	2,000 m ³ /h	10,000 m ³ /h	8.8 Liter/h	1 - 16 bar	Ja
CDE40LC	2,500 m ³ /h	5,000 m ³ /h	25,000 m ³ /h	22 Liter/h	1 - 16 bar	Ja

*1 - standardized to 1 bar(a) and 20°C for operating conditions 7 bar operating pressure, intake air compressor 25°C at 60% relative humidity, 35°C compressed air discharge temperature after-cooler; at deviating operating conditions conversion factors must be applied.



CSD series

Condensate treatment of condensate amounts up to 21.1 litres/hour for residual hydrocarbons of less than 20 mg/litres

Working principle

- ❶ Vent chamber with condensate inlet
- ❷ Sedimentation stage with oil outlet
- ❸ Oil storage filter
- ❹ Activated carbon filter with water outlet

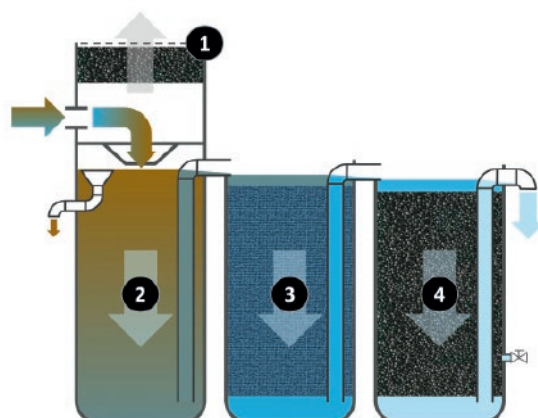

- integrated in one compact unit.

Technical data

Model	Nominal volume flow ^{*1}	Nominal condensate quantity	Connection condensate inlet	Connection water outlet	Connection oil outlet	Height	Width	Depth	Weight empty
CSD3	150 m ³ /h	1.3 Liter/h	1/2	G 1/2	–	555 mm	345 mm	320 mm	9 kg
CSD5	300 m ³ /h	2.6 Liter/h	G1, 3x G 1/2	G 1	–	655 mm	445 mm	430 mm	20 kg
CSD10	600 m ³ /h	5.3 Liter/h	G1, 3x G 1/2	G 1	–	735 mm	495 mm	460 mm	24 kg
CSD20	1,200 m ³ /h	10.5 Liter/h	G1, 3x G 1/2	G 1	–	840 mm	680 mm	510 mm	35 kg
CSD40	2,400 m ³ /h	21.1 Liter/h	G1, 3x G 1/2	G 1	–	985 mm	790 mm	660 mm	67 kg

*1 - standardized to 1 bar(a) and 20°C for operating conditions 7 bar operating pressure, intake air compressor 25°C at 60% relative humidity, 35°C compressed air discharge temperature after-cooler, for non-emulsifying turbine and VDL oils; at deviating operating conditions conversion factors must be applied.

Elements

Filter elements with FST filtration technology – latest and powerful filtration technology for maximum efficiency, reliability and cost-effective operation



The advantages...

- ✓ **Latest pleating-technology**
 - increased separation performance at low differential pressures
 - high dirt holding capacity
 - long service life
- ✓ **Fully integrated design without critical outside media sock**
 - easy maintenance
 - maximum operational reliability
- ✓ **Energy-efficient combination of binder- and binder-free filter media**
 - reduced differential pressure
- ✓ **Optimised media alignment for screw compressors of older and new age (deep drainage)**
 - high separation performance
- ✓ **Qualified for all kind of compressor oils including PAO and PAG oils**
 - maximum operational reliability
- ✓ **Abrasion-free activated carbon filter with 100% activated carbon and integrated dust filtration**
 - long service life
 - reduced differential pressure
- ✓ **Validation according to ISO 12500**



Filter elements with FST filtration technology are available for compressed air filter of:

- **Atlas-Copco** (all series)
- **BOGE** (all series)
- **(Parker) domnick-hunter** (Oil-X Plus, Oil-X Evolution)
- **FST** (all series)
- **Hankison** (HF series)
- **KAESER** (all series)
- **ultrafilter / donaldson** (80-, 90-series)
- **(Parker) ZANDER** (G-, F-series)

Further filter elements are available for compressed air filter of ABAC, AFE, Almig, ALUP, Ceccato, Hiross, Ingersoll-Rand (up to 1995), MTA, Omega Air, Omi, and many others.

Service-Aftermarket



SEWAPAC

Maintenance kits
 for oil/water separators



SEDAPAC

Desiccant and activated
 carbon bundles



SK – Service kits

Maintenance kits



SP – Service parts

Single spare parts



SR – Service repair

Repair kits



SU – Service upgrade

Upgrade kits
 for dryer modernization



Control technology

Controller
 for dryer



Measurement technology

Measurement devices
 and systems

FST GmbH

Sales office: Im Teelbruch 106 – 45219 Essen – Germany

Head office: Weiherdamm 17 – 57250 Netphen-Deuz – Germany

 +49 (0)2054 / 8735-0

 +49 (0)2054 / 8735-100

 info@fstweb.de

 www.fstweb.de

Distributor

COMPRESSED GAS s.r.o., www.compressedgas.sk info@boge.sk

